

# SDD100N18B

## Diode-Diode Modules

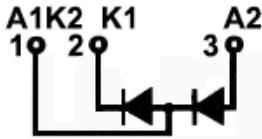

Type	$V_{RSM}$ $V_{DSM}$ V	$V_{RRM}$ $V_{DRM}$ V
SDD100N08B	900	800
SDD100N12B	1300	1200
SDD100N14B	1500	1400
SDD100N16B	1700	1600
SDD100N18B	1900	1800

### Dimensions in mm

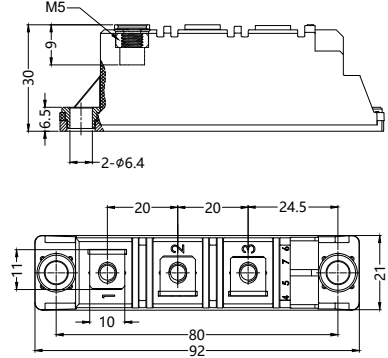

Symbol	Test Conditions	Maximum Ratings	Unit
$I_{FRMS}$ $I_{FAVM}$	$T_{VJ}=T_{VJM}$ $T_C=100^{\circ}\text{C}$ ; 180° sine	180 100	A
$I_{FSM}$	$T_{VJ}=45^{\circ}\text{C}$ $V_R=0$ $t=10\text{ms}$ (50Hz), sine $t=8.3\text{ms}$ (60Hz), sine	1700 1950	A
	$T_{VJ}=T_{VJM}$ $V_R=0$ $t=10\text{ms}$ (50Hz), sine $t=8.3\text{ms}$ (60Hz), sine	1540 1800	
$\int i^2 dt$	$T_{VJ}=45^{\circ}\text{C}$ $V_R=0$ $t=10\text{ms}$ (50Hz), sine $t=8.3\text{ms}$ (60Hz), sine	14450 15700	$\text{A}^2\text{s}$
	$T_{VJ}=T_{VJM}$ $V_R=0$ $t=10\text{ms}$ (50Hz), sine $t=8.3\text{ms}$ (60Hz), sine	11850 13400	
$T_{VJ}$ $T_{VJM}$ $T_{stg}$		-40...+150 150 -40...+125	$^{\circ}\text{C}$
$V_{ISOL}$	50/60Hz, RMS $I_{ISOL} \leq 1\text{mA}$ $t=1\text{min}$ $t=1\text{s}$	3000 3600	V~
$M_d$	Mounting torque (M5) Terminal connection torque (M5)	2.5-4/22-35 2.5-4/22-35	Nm/lb.in.
Weight	Typ.	105	g

**Sirectifier®**

# SDD100N18B

## Diode-Diode Modules

Symbol	Test Conditions	Characteristic Values	Unit
<b>I<sub>R</sub></b>	$T_{VJ}=T_{VJM}; V_R=V_{RRM}$	15	mA
<b>V<sub>F</sub></b>	$I_F=300A; T_{VJ}=25^{\circ}C$	1.5	V
<b>V<sub>Fo</sub></b>	For power-loss calculations only	0.8	V
<b>r<sub>F</sub></b>	$T_{VJ}=T_{VJM}$	2.3	mΩ
<b>Q<sub>s</sub></b>	$T_{VJ}=125^{\circ}C; I_F=50A; -di/dt=3A/us$	170	uC
<b>I<sub>RM</sub></b>		45	A
<b>R<sub>thJC</sub></b>	per diode; DC current per module	0.35 0.175	K/W
<b>R<sub>thJK</sub></b>	per diode; DC current per module	0.55 0.275	K/W
<b>d<sub>s</sub></b>	Creepage distance on surface	12.7	mm
<b>d<sub>a</sub></b>	Strike distance through air	9.6	mm
<b>a</b>	Maximum allowable acceleration	50	m/s <sup>2</sup>

### FEATURES

- \* International standard package
- \* Copper base plate
- \* Glass passivated chips
- \* Isolation voltage 3600 V~
- \* UL file NO.310749
- \* RoHs compliant

### APPLICATIONS

- \* Supplies for DC power equipment
- \* DC supply for PWM inverter
- \* Field supply for DC motors
- \* Battery DC power supplies

### ADVANTAGES

- \* Space and weight savings
- \* Simple mounting
- \* Improved temperature and power cycling
- \* Reduced protection circuits



**Sirectifier®**

# SDD100N18B

## Diode-Diode Modules

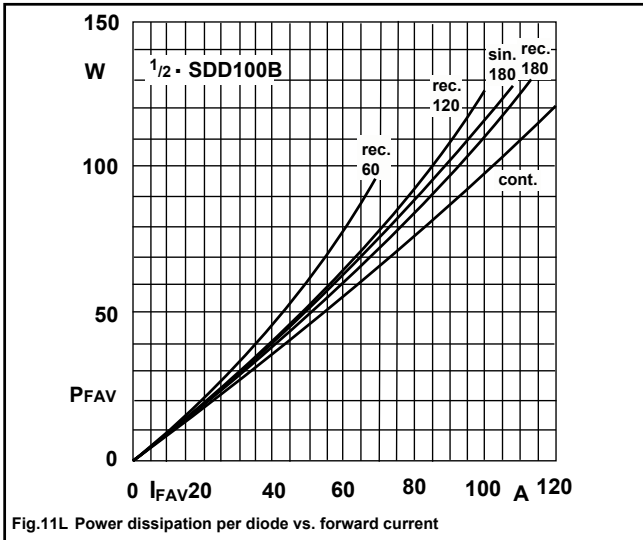

Fig.11L Power dissipation per diode vs. forward current

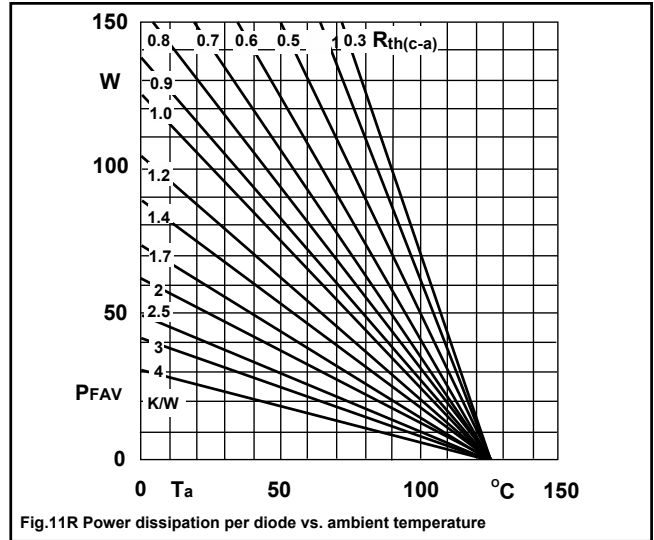

Fig.11R Power dissipation per diode vs. ambient temperature

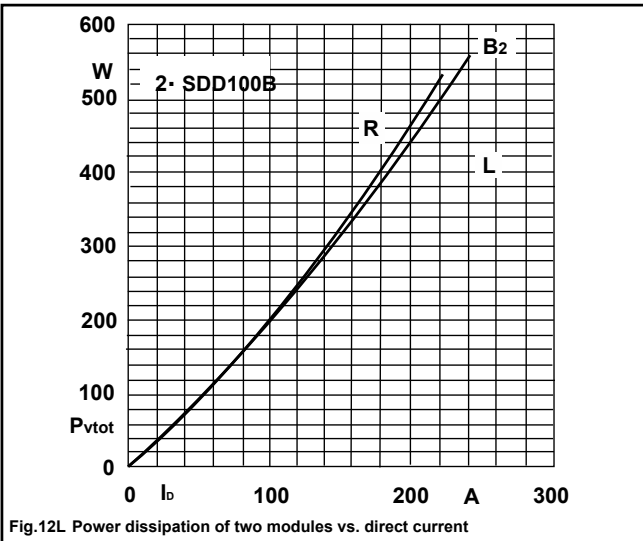

Fig.12L Power dissipation of two modules vs. direct current

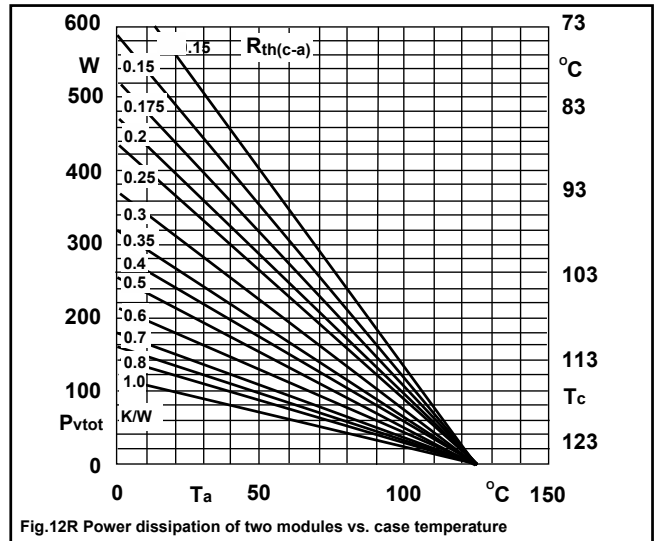

Fig.12R Power dissipation of two modules vs. case temperature

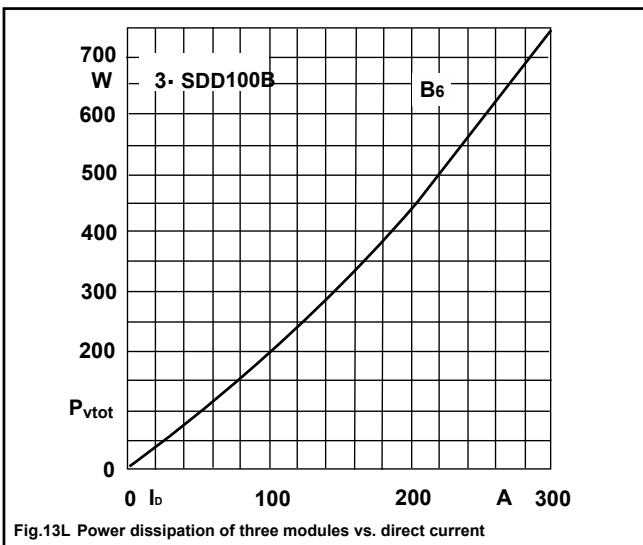

Fig.13L Power dissipation of three modules vs. direct current

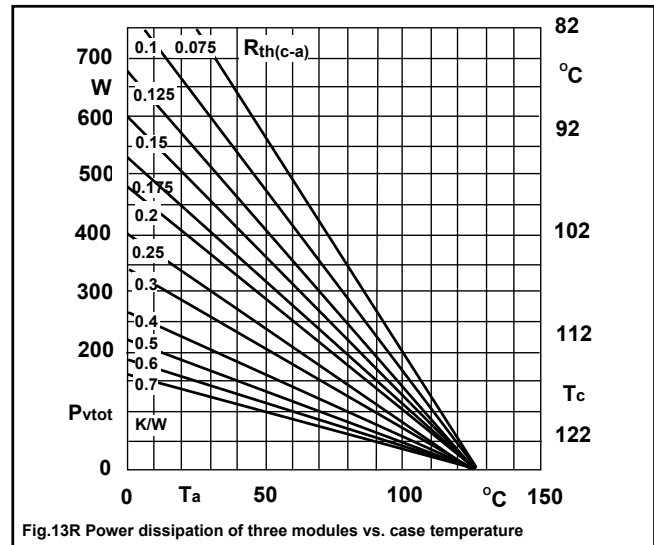

Fig.13R Power dissipation of three modules vs. case temperature



# SDD100N18B

## Diode-Diode Modules

