

S1PDB50NXX

Single Phase Bridge Rectifiers



Dimensions in mm (1mm=0.0394")

Type	V _{RSM} V	V _{RSM} V
S1PDB50N06	700	600
S1PDB50N08	900	800
S1PDB50N12	1300	1200
S1PDB50N14	1500	1400
S1PDB50N16	1700	1600

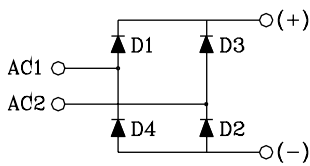
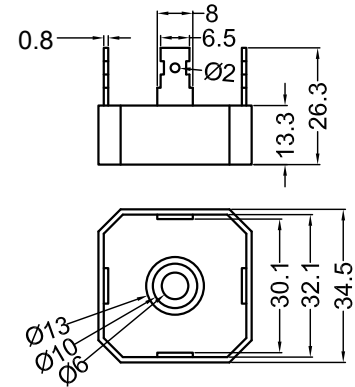

Symbol	Test Conditions	Maximum Ratings	Unit
I _{dav}	T _C =55°C, module	50	A
I _{FSM}	T _{VJ} =45°C V _R =0 t=10ms (50Hz), sine t=8.3ms (60Hz), sine	750 830	A
	T _{VJ} =T _{VJM} V _R =0 t=10ms(50Hz), sine t=8.3ms(60Hz), sine	610 680	
I ² t	T _{VJ} =45°C V _R =0 t=10ms (50Hz), sine t=8.3ms (60Hz), sine	1540 1400	A ² s
	T _{VJ} =T _{VJM} V _R =0 t=10ms(50Hz), sine t=8.3ms(60Hz), sine	1320 1230	
T _{VJ} T _{VJM} T _{stg}		-55...+150 150 -55...+125	°C
V _{ISOL}	50/60Hz, RMS I _{ISOL} ≤1mA t=1min t=1s	2500 3000	V~
M _d	Mounting torque (M5)	3 ± 15%	Nm
Weight	typ.	22	g



S1PDB50NXX

Single Phase Bridge Rectifier

Symbol	Test Conditions	Characteristic Values	Unit
I_R	$V_R=V_{RRM}; T_{VJ}=25^{\circ}C$ $V_R=V_{RRM}; T_{VJ}=T_{VJM}$	≤ 5 ≤ 1000	μA
V_F	$I_F=25A; T_{VJ}=25^{\circ}C$	≤ 1.1	V
V_{TO}	For power-loss calculations only	0.8	V
r_T	$T_{VJ}=T_{VJM}$	3.80	$m\Omega$
R_{thJC}	per diode per module	1.0 0.25	K/W
R_{thJK}	per diode per module	1.2 0.30	K/W
d_s	Creeping distance on surface	10	mm
d_A	Creepage distance in air	9.4	mm
a	Max. allowable acceleration	50	m/s^2

FEATURES

- * Rating to 1600V PRV
- * High efficiency
- * Glass passivated chip junction
- * Electrically isolated metal case for maximum heat dissipation

APPLICATIONS

- * Supplies for DC power equipment
- * Input rectifiers for PWM inverter
- * Battery DC power supplies
- * Field supply for DC motors

ADVANTAGES

- * Easy to mount one screw
- * Space and weight savings
- * Improved temperature and power cycling

Sirectifier[®]

S1PDB50NXX

Single Phase Bridge Rectifiers

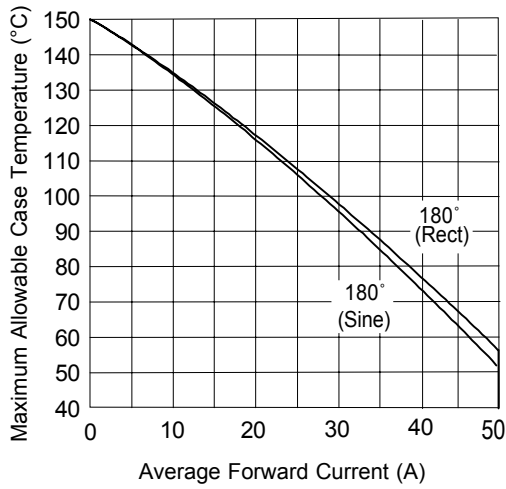

Fig. 1 - Current Ratings Characteristics

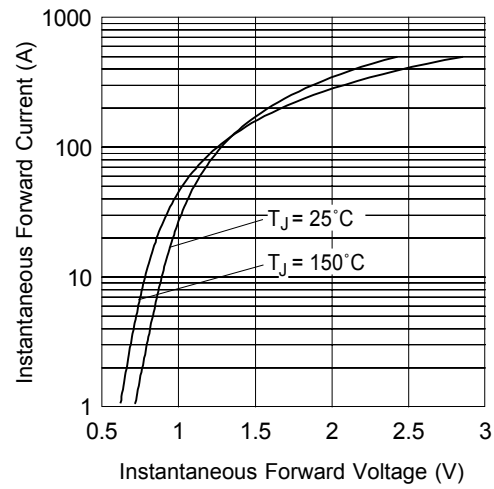

Fig. 2 - Forward Voltage Drop Characteristics

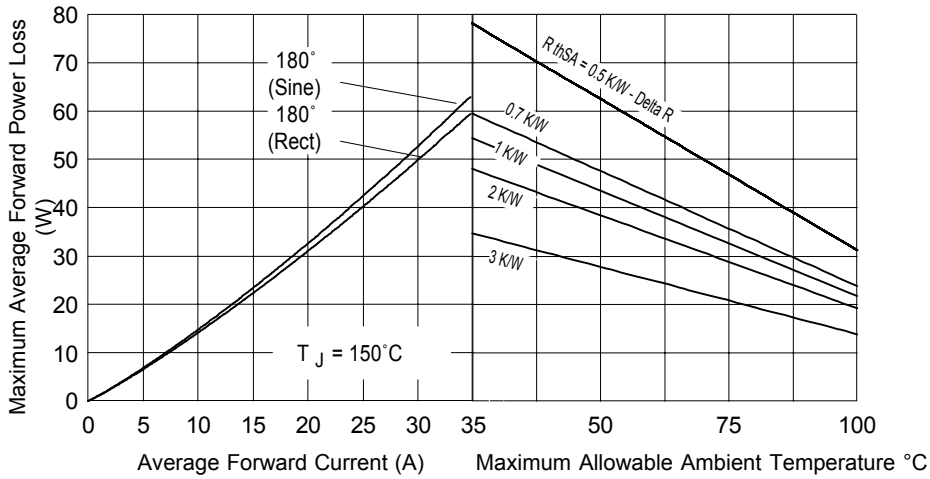

Fig. 3 - Total Power Loss Characteristics

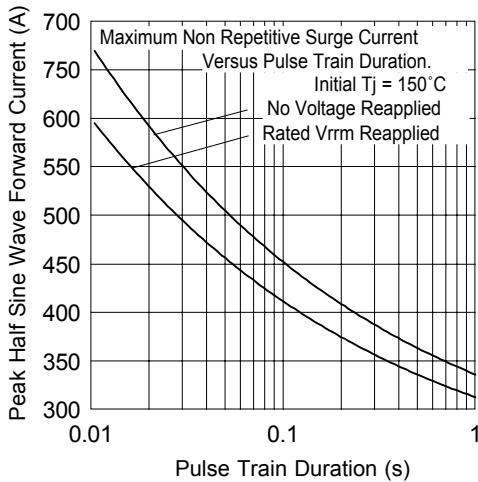

Fig. 4 - Maximum Non-Repetitive Surge Current

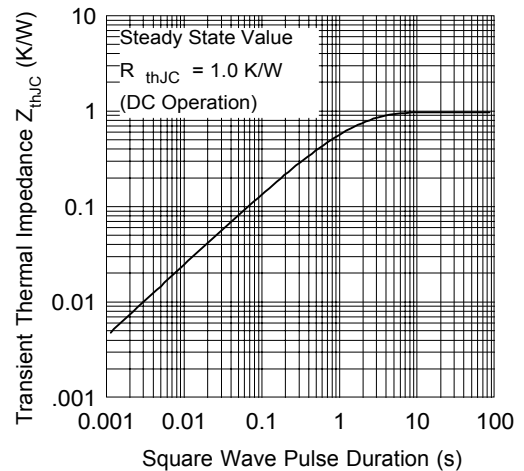

Fig. 5 - Thermal Impedance Z_{thJC} Characteristic

